

ON THE TURBULENT FLOW PAST CAMBERED

BODIES WITH BLOWING.

G. I. SOLATAN , A. A. EL-HADIK & M.A. EL-HEFNY
 السريان الاضطرابي خلف اجسام انسيابية ذات تبريد غشائي

Mechanical Power Engineering Department, Faculty of
 Engineering, Al-Mansoura University, Egypt .

Mechanical Power Engineering
 Department, Faculty of Engineering,
 Alexandria University, Egypt.

الخلاصة :

=====

هذه المقالة تبحث تجريبيا وتحليليا في انتقال الحرارة والموائع حول الحافة الخلفية لريشة توربين غازي مبردة تبريدا غشائيا . في التحليل النظري اعتسّر سريان في الاتجاهين مستقرا ، تدويمي ومضطرب غير منضغط . بواسطة اجراء بعض العمليات الجبرية على كل من معادلات السريان والطاقة امكن استنتاج معادلات شبيهة بالتي استنتجها وقدم باستنتاج الحل لها جوسما واخرون . نموذج الحل المستخدم بواسطة الحاسب الالى هو من نوع استنتاج اللزوجة الديناميكية بواسطة حساب كل من طاقة الاضطراب والجزء الخاص باضعلال تلك الطاقة .

بعض الثوابت المعملية قد اخذت من نتيجة الحل التجريبي وغذى بها برنامج الحاسب الالى لتعطى نتائج نظرية قريبة ما أمكن بالنتائج المعملية وهذا يعطى للحل النظري امكانية التطبيق على حالات اخرى مشابهة .

البحث تم على حالات من السريان المختلفة وذلك في مدى رقم رينولز من 6.25×10^4 الى 1.29×10^5 .

بعمل مقارنة بين كل من النتائج المعملية والمستنتجة بواسطة الحاسب الالى وجد تقارب مرضي بينهما في مدى معمل الحقل من صفر الى الواحد الصحيح (معامل الحقل = النسبة بين سرعة الهواء المحقون الى سرعة الغاز المنساب حول الريشة) .

ABSTRACT- This paper investigates, both experimentally and analytically, the heat and fluid flow around the trailing edge of a film cooled gas turbine blade. In the analysis, steady state, two dimensional, incompressible, recirculating turbulent flow is considered. The momentum and energy equations are derived and transformed to the generalized format of Gosman and et al (2). The kinetic energy and dissipation term of turbulence (i.e. the k-E, model) is considered in the turbulence computational programs. Small number of empirical constants were obtained from both the mathematical model and the conducted experimental work. These mathematical constants provide the most realistic predictions of heat transfer coefficients, when compared with the available experimental data.

The investigation considers varying Reynolds number in the range of 6.25×10^4 to 1.29×10^5 .

There is a satisfactory agreement between the present experimental and theoretical results, for the blowing parameter ($M = U_c/U_{\infty}$) in the range from zero to one.

NOMENCLATURE.

A Cross-Sectional area
 a, b, c, Coefficients in finite difference equation for, Φ_p ,
 & d

C_D, C_u	Empirical constants .
$C_1 & C_2$	
D	Diameter of the blade trailing edge
H	Local heat transfer coefficient, HB; local heat transfer Coefficient in case with blowing, HUB; local heat transfer coefficient in case with no blowing.
i, i	Designates the number of nodes in the x-direction from the origin in finite difference work.
J, j	Designates the number of nodes in the Y-direction from the origin in finite difference work.
k	Turbulence kinetic energy
L	Length scale of turbulence
M	Blowing ratio (U_c/U_∞)
Q	Rate of heat transfer through area A
T	Absolute temperature
U	Time average velocity component in x-direction
U'	Fluctuating component of velocity in x-direction
V	Time-average velocity in y-direction
V'	Fluctuating component of velocity in y-direction
X	Cartesian coordinate, distance measured from the centerline of the trailing edge of blade.
Y	Cartesian coordinate, distance measured normal to the solid boundary.
α	Thermal diffusivity
\sqrt{k}	Diffusivity of turbulent kinetic energy
$\frac{\sigma_k}{\sigma_T}$	The ratio of effective viscosity to effective diffusivity for turbulence energy.
$\frac{\sigma_T}{\sigma_\epsilon}$	The ratio of effective viscosity to effective diffusivity for thermal energy.
σ_ϵ	The ratio of effective viscosity to effective diffusivity for dissipation term of turbulence kinetic energy.
ϵ	Dissipation term of turbulence kinetic energy.
μ	Dynamic viscosity
μ_e	The effective viscosity
μ_T	The turbulence viscosity
ν	Kinematic viscosity
ρ	Density
Φ_P	The parameter stands for $\omega, \nu, T, K, \epsilon$
ψ	Stream function
ω	Vorticity
θ	Temperature parameter $(T - T_C)/(T_\infty - T_C)$
λ	Blade material thermal conductivity.

SUBSCRIPTS

aw	Adiabatic blade surface
b	Properties of flow in the immediate vicinity of the blade surface.
c	Properties of coolant flow
e	Effective
n	Normal to
NP, 1	Properties of flow at second node from the blade surface .
w	Blade surface
2	Properties of flow at third node from the blade surface .
∞	Properties of main stream flow

DIMENSIONLESS GROUP

N_u	Nusselt number ($H \cdot D/\lambda$), Pr. Prandtl number ($\mu \cdot C_p/\lambda$).
R_e	Reynolds number ($U \cdot D/\nu$); St. Stanton number ($N_u/R_e \cdot P_r$).

INTRODUCTION

Recent developments of aircrafts aerodynamic and combustion chambers have required aerodynamic surfaces to withstand considerably high temperature environments. Cooling is used to maintain the surface temperature below that at which severe oxidization occurs. An alternative method, film cooling, is to introduce a thin stream of coolant over these surfaces. The cooling stream forms a thin layer of insulating film between hot gas stream and surfaces.

The study of heat and fluid flow around the trailing edge of a film cooled gas turbine blade is necessary to design blades of long life operation. To neutralize geometry effect on the variation of local heat transfer coefficient around the trailing edge of a film cooled gas turbine blade, two working sets of experiments were conducted. The first was to evaluate the local heat transfer coefficient in the case of no cooling to the blade. While the second set was carried out to investigate the influence of blowing parameter (U_c/U_{∞}) on the local heat transfer coefficient.

Extensive experimental work was conducted by Eckert and Soehngen (8), who studied the flow of air past heated cylinders at Reynolds number ranging from 20 to 500. They found that the highest heat transfer rates occurs at the forward and backward stagnation points. Kays (6), solved the wedge problem and predicted the relationship between the local Reynolds and Nusselt numbers in the two dimensional flow.

Over the last thirty years, a great deal of research works have been carried out to study the mechanics of film cooling. Many theories have been formulated to explain the behaviour of coolant films, and in particular the film cooling effectiveness. The experimental results of these investigations were expressed in empirical formula with large number of empirical constants. Better formulation of the experimental results can be obtained with the help of two dimensional recirculating turbulent flow with coolant injection through slot. This approach gives better insight to the physical problem and facilitates the correlations of experimental data. El-Hadik et. al. (5) used this approach and calculated the local heat transfer coefficient around the leading edge of a film cooled gas turbine blade, for blowing local heat transfer coefficient without blowing is as the following:

- i . Increasing of blowing ratio increases the local heat transfer coefficients ratios.
- ii . The highest value of heat transfer ratio occurs at the re-attachement point.
- iii . Blowing ratios of less than 0.3 cause the blade cooling (i.e. $H_B/H_{WB} < \text{Unity}$).
- iv . Blowing ratios of higher than 0.3 give increase heat transfer ratio higher than unity (i.e. $H_B/H_{WB} > \text{Unity}$).
- v . Careful formulation of the boundary conditions around the domain of analytical solution is essential to obtain acceptable results.

The present work studies the heat transfer and fluid flow around the trailing edge of a film cooled gas turbine blade both theoretically and experimentally. The coolant is injected through a slot located in the mid of the trailing edge of turbine blade, which is immersed in a cross stream as shown in Fig. (1). Theoretical, two-dimensional viscous, turbulent, recirculating, and steady flow is considered. The local velocity components (U & V) at the boundaries of control volume are measured by using a calibrated X-Y probe hot-wire anemometer and feeded to the computer programme for getting on an agreeable results. Finally the local heat transfer coefficients ratios are calculated experimentally and also computed by using (k - ξ) turbulent model. The computer programme was run at the Cairo University Computer Center. Study of heat and fluid flow around the trailing edge of a film cooled gas turbine blade, includes the effect of blowing parameter and various Reynolds number.

EXPERIMENTAL STUDY:

Aim of the experiment is to measure the surface temperatures of the trailing edge of a film cooled gas turbine blade. A heated model of the trailing edge surface was made from five electrically conducting foils. Each foil has a rectangular shape of 240 mm length, 4 mm width and 0.3 mm thickness. The electrical resistivity of foils metal is 47 ohm/ Cm.

The foils were glued to a perspex rectangular sheet having 292 mm length, 60 mm height and 6 mm thickness. To blow the air, a slot of 210 mm length and 0.25 mm width has been machined in the middle of perspex sheet. The foils were connected in series of forming a two dimensional plane as shown in Fig.(2). A thermocouple was soft soldered at underside surface of each foil and at the midpoint of its length. Finally the surface grooves resulted from the assembly of the heater were filled with plastic filler compound and the surface sandpapered smooth. The manufactured model was then allocated downstream the flow close to the working section exit of a wind tunnel. Experiment rig was constructed as shown in Fig.(3) at the university of El-Mansoura, mechanical engineering department in heat transfer laboratory. In the operation of the wind tunnel the main air stream was drawn by an electric driven centrifugal fan to the wind tunnel through a wire mesh and bell mouth inlet. The driven fan is followed by a graduated throttle valve to regulate the air flow. The main stream velocity was measured by using a mid channel pitot-tube and wall static tappings. The blowing air was provided by an electric driven air compressor. Its flow rate was measured by using a float-meter. The blowing air was heated upto 77 °C by a thermostatic electrical heater, while the main stream temperature was recorded at 27 °C. The current passing through the strips was adjusted to give a convenient range of temperatures across the surface, typically 20 °C above ambient temperature.

After a steady state condition was reached, the local temperatures measured by each thermocouple were recorded and called wall temperatures (T_w). Also, the local adiabatic wall temperatures (T_{aw}), were measured when no heating is applied to the strips. These adiabatic wall temperatures, are not only a function of the geometry and primary and secondary flow fields, but also a function of the temperatures of the two gas streams.

Corrections were made to account for the losses by radiation and transverse conduction and for temperature readings to allow for the temperature drop across the wall.

Finally, the local heat transfer coefficients ratios were calculated by using the obtained data at various Reynolds numbers and blowing parameter ratios.

ANALYTICAL SOLUTION:

An analytical study of heat and fluid flow around the trailing edge of a film cooled gas turbine blade in the region close to the point of coolant injection is considered in this study. Effect of blowing parameter is focussed in this study. The problem to be considered is illustrated diagrammatically in Fig.(1-b). To cancel the effect of geometry, two sets of analysis were conducted, one to determine the local heat transfer around the trailing edge of a blade with no cooling, while the second is to calculate the local heat transfer coefficient when cooling is considered for the same conditions. Cooling of the trailing edge of a blade is effected by the injection of air through a slot located in the stagnation area of the trailing edge. In the flow downstream the slot as indicated in Fig. (1-b), there is a separation, recirculation and reattachment in the immediate vicinity of the point of injection. In general, the flow can be considered, two dimensional, viscous, and turbulent. In case of blade cooling two computer programs were used to determine the local heat transfer coefficient. The first one is used to compute the local adiabatic wall temperature, while the second is used to calculate the local heat transferred between the blade surface and gas stream. In computation, the basic conservation equations are used to find the domain of integration and the boundary conditions for the problem.

The basic conservation equations, continuity, momentum, and energy in two dimensional as well as the equations and terms for vorticity, streams function, turbulence energy, and turbulence energy dissipation rate are given as follows:

$$\omega = \frac{d v}{d x} - \frac{d u}{d y} \quad (1)$$

$$\frac{d u}{d x} + \frac{d v}{d y} = 0 \quad (2)$$

$$u = \frac{d \psi}{d y} ; v = - \frac{d \psi}{d x} \quad (3)$$

$$u \frac{d u}{d x} + v \frac{d u}{d y} = - \frac{1}{\rho} \frac{d p}{d x} + \frac{d}{d x} (\nu \frac{d u}{d x}) + \frac{d}{d y} (\nu \frac{d u}{d y}) - (\frac{d \bar{u}^2}{d x} + \frac{d \bar{u} \bar{v}}{d y}) \quad (4)$$

$$u \frac{d v}{d x} + v \frac{d v}{d y} = - \frac{1}{\rho} \frac{d p}{d y} + \frac{d}{d x} (\nu \frac{d v}{d x}) + \frac{d}{d y} (\nu \frac{d v}{d y}) - (\frac{d \bar{v}^2}{d y} + \frac{d \bar{v} \bar{u}}{d x}) \quad (5)$$

$$u \frac{d T}{d x} + v \frac{d T}{d y} = \frac{\nu_e}{G T} (\frac{d^2 T}{d x^2} + \frac{d^2 T}{d y^2}) \quad (6)$$

$$u \frac{d k}{d x} + v \frac{d k}{d y} = \frac{d}{d x} (\frac{\nu_e}{G k} \frac{d k}{d x}) + \frac{d}{d y} (\frac{\nu_e}{G k} \frac{d k}{d y}) - G - \epsilon \quad (7)$$

$$u \frac{d \epsilon}{d x} + v \frac{d \epsilon}{d y} = \frac{d}{d x} (\frac{\nu_e}{G \epsilon} \frac{d \epsilon}{d x}) + \frac{d}{d y} (\frac{\nu_e}{G \epsilon} \frac{d \epsilon}{d y}) - \frac{C_1 G \epsilon}{k} - \frac{C_2 \epsilon^2}{k} \quad (8)$$

Where

$$G = \nu_T \left\{ 2 \left[\left(\frac{d u}{d x} \right)^2 + \left(\frac{d v}{d y} \right)^2 \right] + \left[\frac{d u}{d y} + \frac{d v}{d x} \right]^2 \right\} \quad (9)$$

The turbulence viscosity is related to the turbulence energy and its dissipation rate term by the following relationship:

$$\nu_T = C_\mu k^2 / \epsilon \quad (10)$$

Also, the turbulence dissipation rate can be shown by dimensional analysis, equal to:

$$\epsilon = C_D k^{3/2} / L \quad (11)$$

Where, C_D is constant, and may be considered in this problem equal to 0.22, while L is a turbulence length scale.

Before proceeding to numerical solution, the number of differential equations to be solved were reduced by introducing the stream function ψ , and vorticity ω , into these equations, (4,5,6,7 & 8). Also the pressure term was eliminated as a variable by differentiating the x and y momentum equations (4 & 5) with respect to y and x respectively and subtracting. By this way a closed set of five equations have been derived and their simultaneous solution gives prediction of momentum transport in a general turbulent flow. It may be noted that five constants were introduced in the development of the ($k-\epsilon$) turbulent model. Approximate values have been assigned to these constants by a combination of physical arrangement consideration of simple flow, and by comparing the theoretical with experimental predictions. A computer program was written to find these constants by comparing the results obtained by the use of the constants and the experimental results to most agreeable values. The obtained values are as follows:

$$C_1 = 1.66; C_2 = 2.04; C_\mu = 0.09; \bar{G}_k = 1; \bar{G}_\epsilon = 1.3; \bar{G}_T = 0.95. \quad (12)$$

Finally, the five equations were solved numerically in cartesian coordinates appropriate to the film cooling problem. It is noticed that the equations possess much similarity in form, a fact which was helpful in programming the numerical solution procedure.

The general form of the governing equations may be casted as the following:

$$a \left[\frac{d}{dx} \left(\Phi_p \frac{d\psi}{dy} \right) - \frac{d}{dy} \left(\Phi_p \frac{d\psi}{dx} \right) \right] - \frac{d}{dx} \left[b \left(\frac{d(c \Phi_p)}{dx} \right) \right] - \frac{d}{dy} \left[b \left(\frac{d(c \Phi_p)}{dy} \right) \right] + d = 0 \tag{13}$$

Comparison of the finally five developed conservation turbulent flow equations of a film cooled trailing edge of the gas turbine blade, with the generalized equations gives the functions of Φ_p , a, b, c, and a as given in the following table:

Φ_p	a	b	c	d (source term)
ω	1	1	1	0
ψ	0	1	1	$-\omega$
T	1	$\nu + (\nu_T / \sigma_T)$	1	0
K	1	$\nu + (\nu_T / \sigma_K)$	1	$-(G + \xi)$
ξ	1	$\nu + (\nu_T / \sigma_\xi)$	1	$-(C_1 G_\xi + C_2 \xi^2) / k$

The variables to be obtained numerically from the solution, are ω , ψ , T, K and ξ . The values of these variables at the boundary conditions are required to carry out the numerical solution. Reliable values at the boundary condition shall form the input to the computer programs. Some of these values were found experimentally. For example, the components velocities were measured by using x-y hotwire anemometer probes. For the purpose of calculations, two sets of wall temperature boundary conditions were considered. To calculate the local temperature of adiabatic wall, the temperature gradient normal to the blade surface should be equal zero. When the local heat transfer between the wall and stream is to be computed at the trailing edge surface a wall temperature was assumed.

The used boundary conditions values are plotted in Figs. (4-a, and 4-b).

Finally the computer programmes which are attached and of this paper were written in FORTRAN and run at IBM computer centre of Cairo University. Each run has been taken 683 seconds, and 2500 iteration number.

RESULTS AND DISCUSSION

The present work is concerned with an investigation of fluid flow and heat transfer around the trailing edge of a film cooled gas turbine blade. Of special interest is the influence of injection of cooled air from a slot located in neighbouring the stagnation point of the trailing edge of blade, and therefore attention is focussed on the determination of the variation of local heat transfer coefficient in this region.

Also an experimental study on film cooling trailing edge gas turbine blade has been carried out with injection of hot secondary air through a slot (210 x 0.25 mm) located in the stagnation point of that trailing edge.

Figure (5) shows a typical theoretical distribution of stream function and non-dimensional temperature, θ , obtained using the numerical procedure. An interesting feature of the flow field at relatively large blowing rates is the recirculation zone with reattachment downstream of the injection point.

The shape of the isotherms in Fig.(5) is consistent with this pattern, the colder main stream fluid being drawn towards the surface and circulations appears behind the blade.

The influence of blowing is examined more conveniently if the ratio of the heat transfer coefficients in cases with and without blowing is used. Figure (6) shows this ratio for various positions according to experiment and the prediction using the $(k - \xi)$ model. It will be observed that both theory and experiment exhibit a maximum point in the vicinity of reattachment and that blowing may produce local increase in h_{WB}/h_B upto 40 per cent.

For small blowing rates, it is to be noticed that the heat transfer coefficient may decrease because of a decrease in velocity along the surface.

Further comparison between theory and experiment is made in Figs. (6-a), (6-b), (6-c), (6-d) at different Reynolds numbers. The programme of work involved other aspects of the problem, including for example the prediction of kinetic energy. These additional topics are covered fully in reference (5), where the whole problem is dealt within much greater detail in regard to both experimental and theoretical aspects of the investigation in case of leading edge.

6- CONCLUSIONS AND RECOMMENDATIONS.

Film cooling and heat transfer has been investigated with particular reference to the influence of fluid injection on the heat transfer coefficient in the vicinity of the trailing edge of a gas turbine blade. New experimental data have been obtained and compared with the results of a numerical prediction for turbulent recirculating flow.

It has been established that over the range of variables studied and for the particular geometry.

- i. Injection may have a significant influence on the flow.
- ii. For large blowing rates an increase of upto 40 per cent may occur in the value of local heat transfer coefficient.
- iii. A maximum value of the heat transfer coefficient occurs in the vicinity of the reattachment point.
- iv. Small blowing rates may produce a decrease in the heat transfer coefficient.

In view of the importance of this field of study, geometry using inclined discrete holes and variable property flows should be studied, and three dimensional flow may be considered.

REFERENCE :

- 1- Goldestein, R.J., ADVNACES IN HEAT TRANSFER, Academic Press, 1971.
- 2- Gosman, A.D., Pun, W.M., Runchal, A.K., Spalding, D.V., and Wolfshtein, M., HEAT AND MASS TRANSFER IN RECIRCULATING FLOWS. Academic Press, 1969.
- 3- EL-HADIK A.A.B., AN INVESTIGATION OF FLOW AND HEAT TRANSFER AROUND THE LEADING EDGE OF A FILM COOLED GAS TURBINE BLADE, Ph.D. thesis, University of Liverpool. 1980.
- 4- Russell, M. and Hatton, A.P., TURBULENT FLOW CHARACTER-ISTICS OF AN IMPINGING JET, Proc.Inst. Mech. Engrs. Vol. 186, PP. 52-72, 1972.
- 5- EL-HADIK, A.A.B. and Araid, F.F. A NUMERICAL SOLUTION FOR TURBULENT FLOW AROUND THE LEADING EDGE OF A FILM COOLED GAS TURBINE BLADE ASME. JSME THERMAL Engineering. Joint Conference, Vol. 4. 1983.
- 6- Kays W. M. CONVECTIVE HEAT AND MASS TRANSFER OATA, McGraw-Hill Publishing Company Ltd. New Delhi-(1975).

- Soltan, A STUDY OF HEAT TRANSFER AROUND THE TRAILING EDGE OF A FILM COOLED GAS TURBINE BLADE. M. Sc. thesis, Faculty of Engineering, University of EL-Monsoura, Egypt., 1985.
- Eckert, E.R.G., and E. Soehngen, INTER FEROMETRIC STUDIES ON STABILITY AND TRANSITION TO TURBULENCE OF FREE CONVECTION BOUNDARY LAYER, Proc. Gen. Discuss. Heat Transfer ASME-IME, London, 1951.

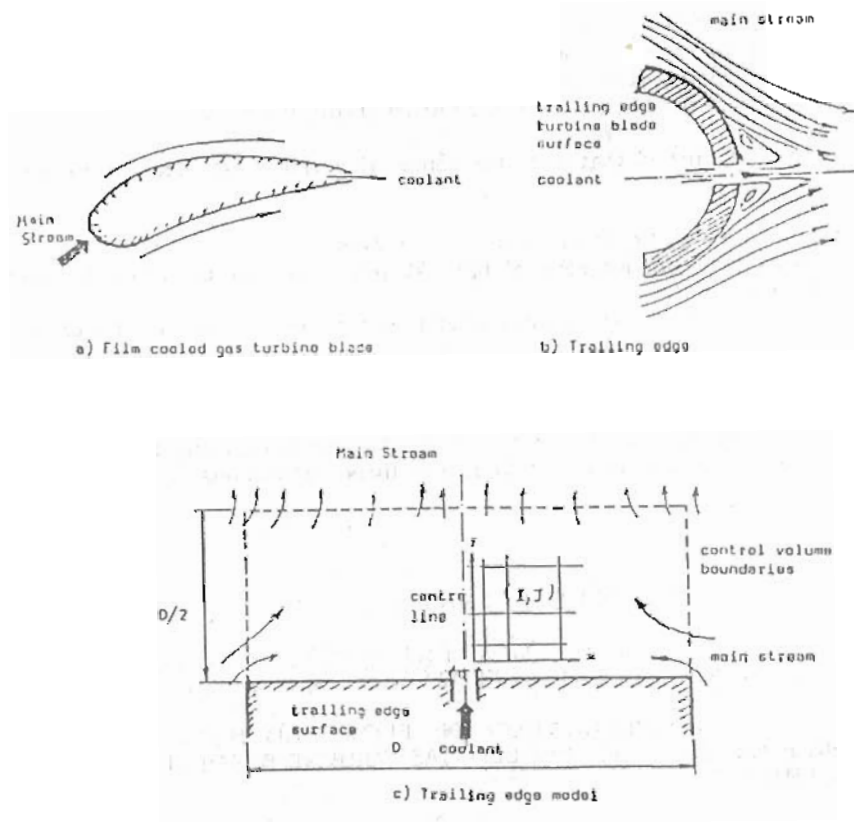

Fig. (1) A trailing edge of a film-cooled gas turbine blade and its model

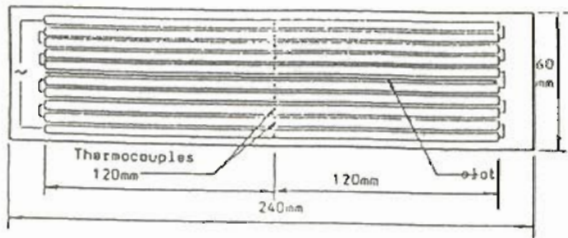

Fig. (2a) HEAT TRANSFER EXPERIMENTS

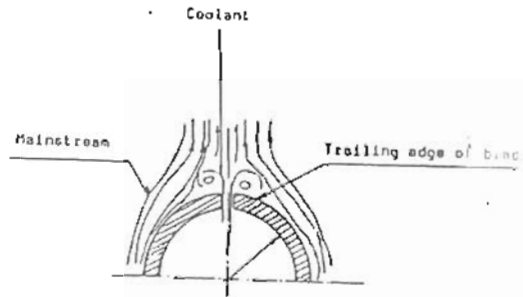
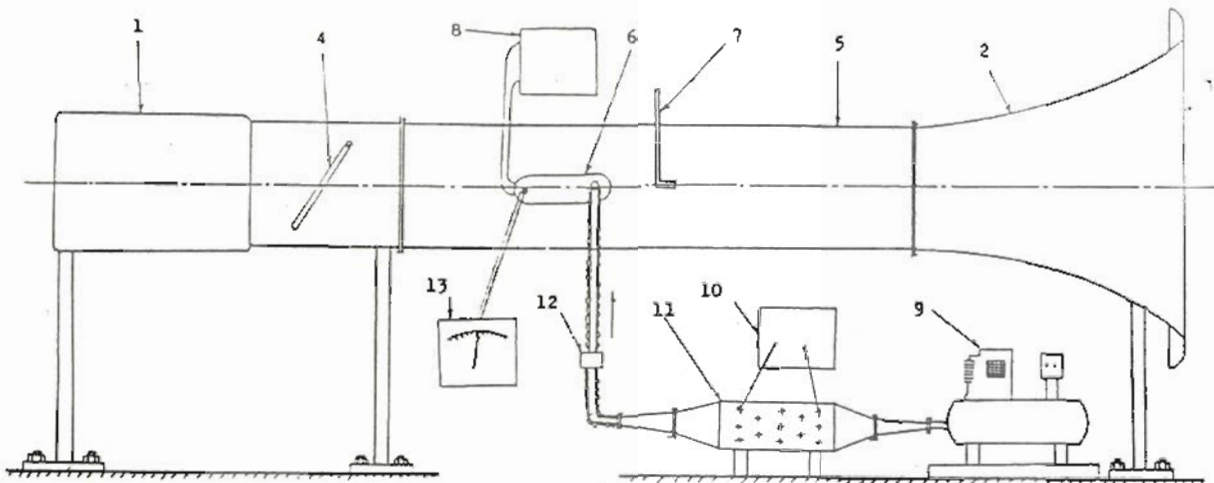

Fig. (2b) Cooled gas turbine blade



- 1- Wind tunnel fan .
- 2- Wind tunnel bell mouth inlet .
- 3- Screen .
- 4- Regulator valve .
- 5- Wind tunnel .
- 6- Test section .
- 7- Pitot tube .

- 8- Transformer .
- 9- Compressor .
- 10- Transformer .
- 11- Electric heater .
- 12- Gasmeter .
- 13- Temperature recorder .

Figure (3) Layout of the apparatus and measuring instruments .

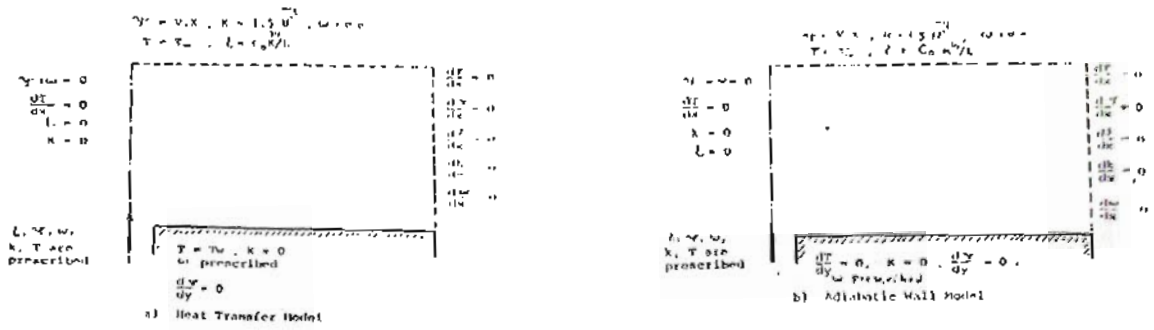

Figure(4) Boundary Conditions

MESH SIZE: 11 x 21 T = 300 °k
 --- Stream lines $\theta = \frac{T - T_c}{T_\infty - T_c}$
 --- Isothermal lines M = 1.1

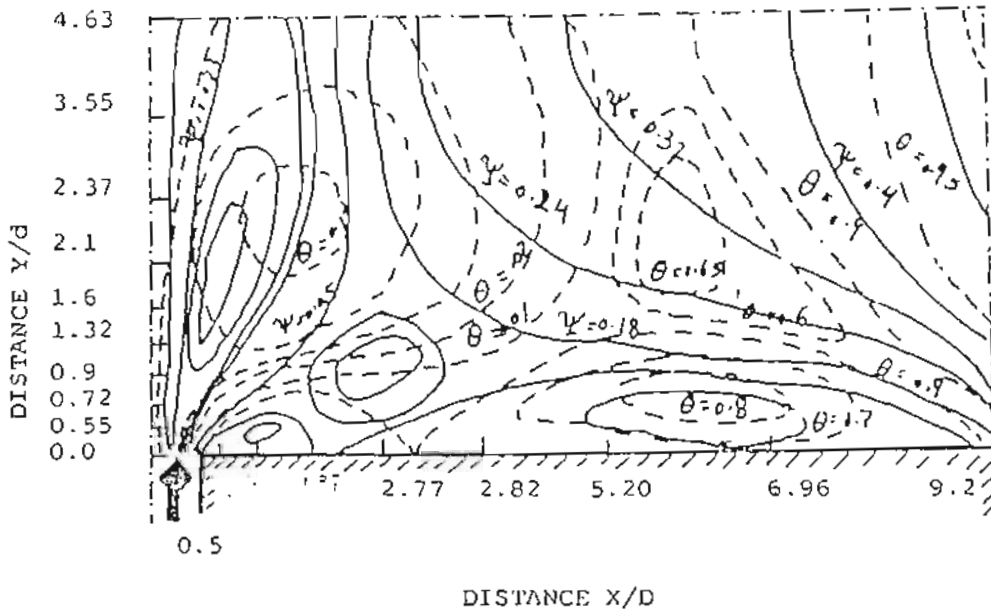

Figure(5): Streamlines and Isotherms for adiabatic wall temperature case in two-dimensional flow. (turbulent and K- ϵ model). Blowing parameter 1.1, and Reynolds number 1.05×10^5 .

— Experimental Results
 - - - Analytical Results

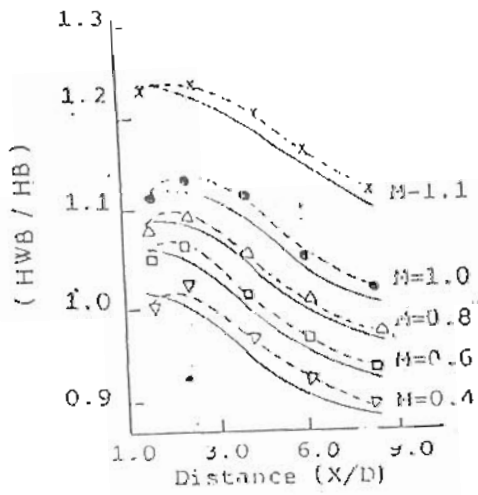

Fig.(6-a): At $Re = 25 \times 10^4$

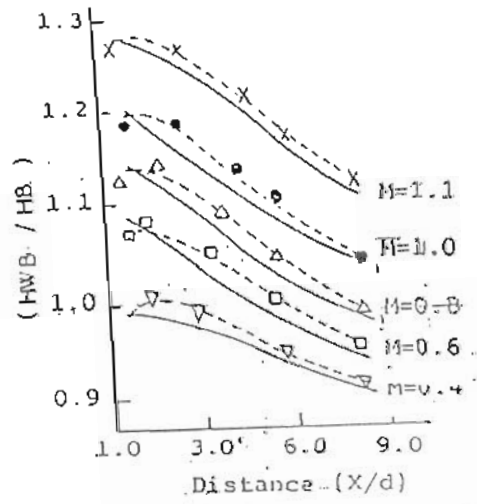

Fig.(6-b): At $Re = 8.375 \times 10^4$

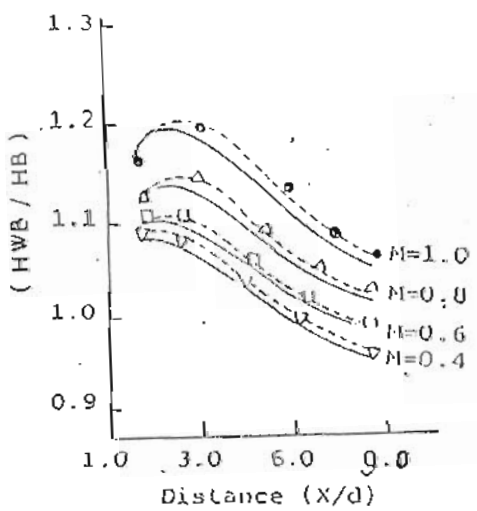

Fig. (6-c) At $Re = 1.05 \times 10^5$

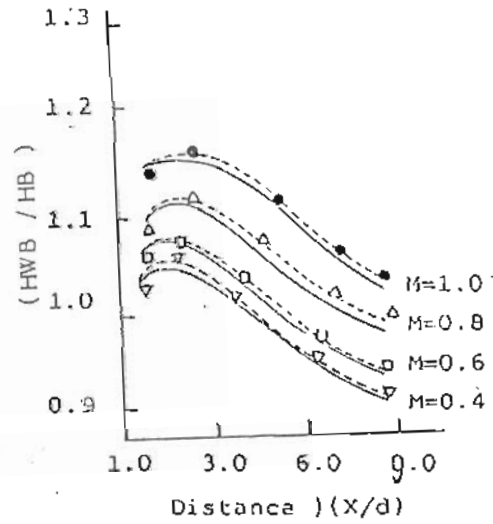

Fig.(6-d): At $Re = 1.129 \times 10^5$

Fig.(6): Relative magnitude ratios between the local heat transfer coefficients with and without blowing for various blowing parameter and Reynolds number.